

User Manual

Version 1.2

English

Contents

Keypad	2
Display	2
How to Use the Instrument	3
Functions	7
User Information	11
Safety Instructions	12
Technical Data	18
Message Codes	18

DISTO classic⁵ hand-held laser meter

Congratulations on your purchase of a DISTO.



This User Manual contains important safety directions (see section "Safety directions")

as well as instructions on use of the instrument.

Read carefully through the User Manual before you switch on the instrument.

Product identification

The identification label for your product is fitted on the front. The serial number is in the battery compartment.

Enter model and serial number in your User Manual, and always refer to this information when you need to contact your agency or service centre.

Model: DISTO

Serial no.:

Date of purchase:

Symbols used

The symbols used in the User Manual have the following meanings:



WARNING:

Indicates a potentially hazardous situation or an unintended use which, if not avoided, will result in death or serious injury.



CAUTION:

Indicates a potentially hazardous situation or an unintended use which, if not avoided, may result in minor injury and/or in appreciable material, financial and environmental damage.



Important paragraphs which must be adhered to in practice as they enabled the product to be used in a technically correct and efficient manner.

Keypad

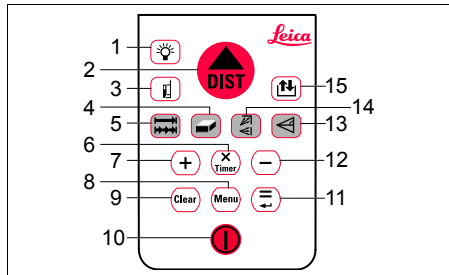

D5-Z1

- | | |
|-----------------------------------|-------------------------|
| 1 Illumination | 9 Clear |
| 2 Measuring | 10 On/off key |
| 3 Meas. reference | 11 Equals, Enter |
| 4 Areas, Volumes | 12 Minus [-] |
| 5 Distance measuring,
Tracking | 13 Pythagoras functions |
| 6 Multiply [x]/Timer
Release | 14 min. / max. Tracking |
| 7 Plus [+] | 15 Memory, Stack |
| 8 Menu | |

Display

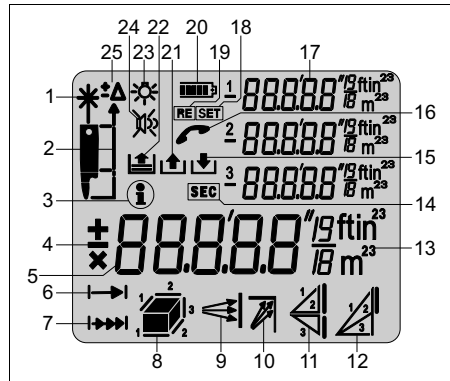

D5-Z2

- | |
|--|
| 1 Laser "on" |
| 2 Measurement reference (front/ stand/ rear) |
| 3 Information |
| 4 Display of the mathematical signs/operations |
| 5 Main display (e.g. measured distance) |
| 6 Distance measurement |
| 7 Tracking |

- | |
|---|
| 8 Area/ Volume |
| 9 min. Tracking |
| 10 max. Tracking |
| 11 Pythagoras function |
| 12 Pythagoras function with partial height |
| 13 Units with exponents (² / ³) |
| 14 Time symbol for time delay release |
| 15 Save constant |
| 16 Contact customer service |
| 17 3 auxiliary displays (e.g. previous values) |
| 18 SET |
| 19 RESET |
| 20 Battery display |
| 21 Recall stored constant (max. 10) |
| 22 Recall last 15 values |
| 23 Illumination (on/ off) |
| 24 Beep (on/ off) |
| 25 Offset setting |

How to Use the Instrument

Inserting / replacing the batteries

- 1 Depress the locking clip and slide end piece to the right.

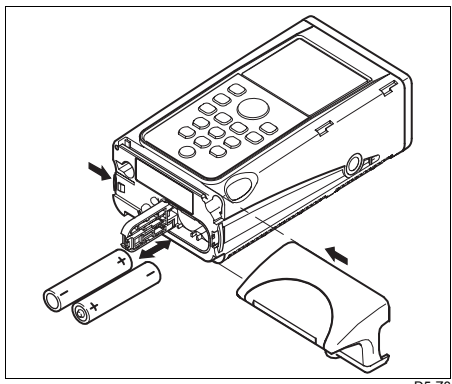

D5-Z3

- 2 Remove battery cover. Replace batteries.
-  Appears on the display if battery voltage is too low.

For type of battery, refer to Technical Data.

 Fit batteries the right way round.

 Use only Alkaline batteries.

- 3 Push in end piece and listen for locking click sound.

DISTO Switching on/off

 Briefly press.

The illumination, Battery and Beep symbols are displayed until the first key press. The instrument can be switched off from any menu point.

 The instrument switches off automatically after 90 seconds if no key is pressed.

Clear key

 The clear key resets the instrument to Normal Mode, i. e. it is set to zero (=Clear).

The clear key may be pressed before or after a measurement/ calculation.

In Menu Mode it resets to Normal Mode.

During a function (area, volume or Pythagoras) the single measurements can be deleted step by step and remeasured.

Used to exit menu settings without saving changes.

Illumination

 Briefly press.

Illumination is switched on/off with a key press.

 Illumination switches off after 30 seconds if no key is pressed.

Reference setting



Press until desired reference setting appears.

Possible settings

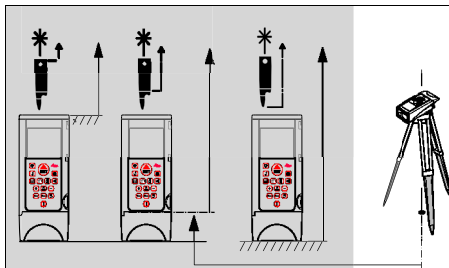

D5-24

front stand rear

At the back of the instrument is a 1/4" camera thread for the stand.

Changes are lost when instrument is switched off.

Basic setting: rear reference

Measuring

Distance measurement



Press and the laser is switched on, the instrument is in "Pointing Mode".



A second press starts the distance measurement.

The result is displayed immediately in the selected unit.

With the instrument on and the laser off, it is in "Normal Mode".

With the laser on, it is in "Pointing Mode".

Measuring from flat planes

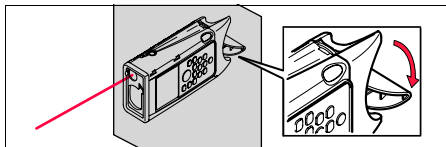

D5-25

For stable measuring turn bumper 90°.

Measuring from corners

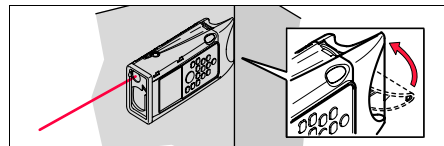

D5-26

Continuous measurement (Tracking)



Press until



appears on the display.



Continuous measurement is started and the result is displayed.



Press to end Tracking Mode. Last result is shown in the display.

Example: Stake off distance

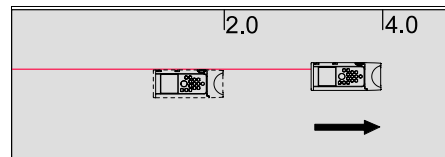

D5-27

Laser in continuous operation



Press until a long "beep" is heard. Now the laser is activated permanently.



A distance measurement is triggered each time the key is pressed.



Press to end continuous laser operation.

Time delay release

Instrument must be in Pointing Mode.



Press and hold until desired time delay has been reached (max. 60 seconds).



appears on the display.

Once the key is released, the remaining seconds (e.g. 59, 58, 57...) are displayed, until measuring.

The last 5 seconds are counted down with a "beep".

After the last "beep", the measurement is made and the value displayed.

: Measuring without any key activation.

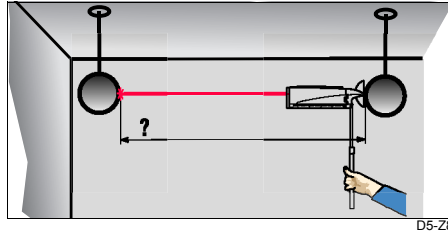

D5-Z8

Calculations

Area



Press until



appears on the display.
The side to be measured blinks.

Make 2 measurements (l x w).

The result and the two partial results appear on the display.

Volume



Press until



appears on the display.
The side to be measured blinks.

Make 3 measurements (l x w x h).

The result and the three partial results appear on the display.

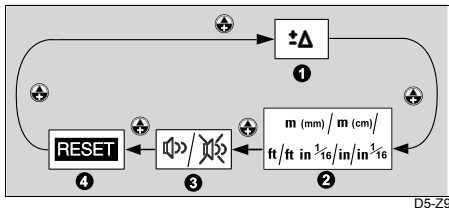

Menu/Settings

With this menu settings on the user level are possible. The user can configure the instrument to his/her own specific and personal needs.





- 1 Measure with offset (add/reduce)
- 2 Selecting measuring units
- 3 Beep
- 4 Reset

Calling up a menu:

-  Press until desired menu point appears or with key [+ / -] switch between the various menu points.
-  Confirm selection, activate menu point.

 or with key [+ / -] change setting as desired.

 Confirm selection, reset to Normal Mode.

 "Clear Entry" may also be used (e.g. to cancel a selection).

Selecting units

Selectable units:

- m (mm) = 0.000 m
- m (cm) = 0.00 m
- ft = 0.00 ft
- ft in 1/16 = 0.00 1/16 ft in
- 14' 06" 1/16 = ' ' 1/16
- in = 0.0 in
- in 1/16 = 0 1/16 in

Measure with offset

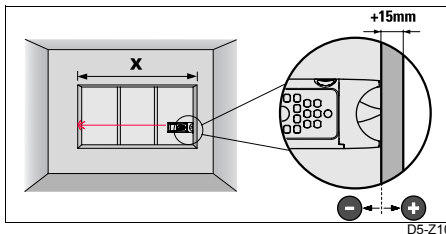

Call up menu point.

 blinks on the display.

With key [+ / -] set desired offset (=shifting reference) (e.g. 0,015m); quick set by keeping key pressed.

 For larger steps hold additionally.

 Offset can be positive (add) or negative (reduce)!

 Confirm setting.

 Is displayed continuously if offset \neq 0.

 Subject to set offset, the measured results are displayed.

Using this function you can measure with rough size, as an example!

Please make this a rule: After rough size measurement always set the DISTO to offset 0.000: Call up function as described

 Press.

 Confirm function.

 After making/changing settings, it is imperative that a test measurement is performed.

Resetting

Call up menu point.

RE SET starts blinking on the display.

With key [+ / -] select components to be reset. To choose from:

 Stack/ Memory

 Stack and Constant

If additional symbols, e.g. measuring frequency and units are shown in the display, the following values are reset:

- Offset (=0), Beep (On) and Units (meter)

 Selected components are reset; back to Measuring Mode.

Functions

Save values (constants)

Measure/ calculate desired value (e.g. height of room, area, volume).

 Press longer.

 starts to blink on the display.

With key [+ / -] adjust value as desired (e.g. from 2.297m to 2.300m).

 For larger steps press and hold additionally.

 Press to adjust unit (2³).

 The adjustment is for m, m² and m³ rsp. ft, ft² and ft³ only.

 Confirm.

 and a number (=memory location) starts to blink.

With key [+ / -] select memory location (1-10).

 Save value.

Recalling the constant

 Press briefly.

 and the contents of the first constant memory location are displayed (e.g. 2.300m).

With key [+ / -] select desired memory (1 to 10).

 Confirm; value is ready to be used for (e.g. calculating an area) or

Recall last measured value (Stack)

 Briefly press twice

 and the last value in the display is shown.

With key [+ / -] select desired value (max. 15!).

 Confirm; value is ready to be used for (e.g. calculating an area).

Tracking - Minimum

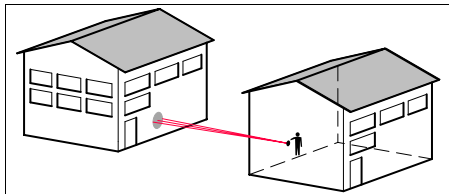

Determine the minimum dimension, e.g. ceiling height, without having to precisely align to the normal.



Press until



appears on the display.

Aim DISTO approximately at the target point.



Activate continuous measurement with a brief press.

Move the DISTO a large amount around the target point.



Stop continuous measurement.

The smallest measurement is displayed (e.g. 3.215m = height of room).



Both planes (e.g. floor/ ceiling, walls) must be nearly parallel to each other.

Tracking - Maximum

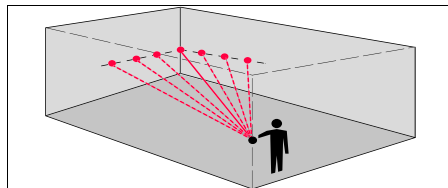

Determine maximum dimension, e.g. to determine the (room) diagonal.



Press until



appears on the display.

Move the DISTO a large amount around the target point.



Activate continuous measurement with a brief press.

Slowly rotate the DISTO to the right/ left past the corner.



Stop continuous measurement.

The largest measurement is displayed (e.g. 12.314m = diagonal of room).

Calculations

Partial heights, partial distances

Make measurement.

Add by [+] key/ Subtract by [-] key.

Make additional measurements.



= Result.



In the same way **chain values** (= any amount of distance measurements) and sums of areas/ volumes can be added up.



During calculations "Clear" is available as long as the function has not been executed!

Multiplication

Make measurement (e.g. 8.375m).

Multiplication by pressing [x] key.

Additional measurements (e.g. 8.375m).

 = Area (e.g. 29.313m²)

 The volume can be calculated by an additional multiplication following an area calculation.

This function can be used for calculating areas or volumes with individual partial heights/ partial distances.

Doubling a measured value

It is easy to double the measured values, e.g. to determine the length of walls in a room:

Make measurement.

Add by [+] key.

Make additional measurements.

 = Sum (=half circumference)

With key [+] repeat, double measured value.

 = Sum (=circumference)

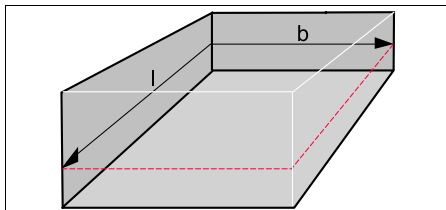

D5-Z13

Pythagoras, height/ width measurement

 The measuring sequence must be adhered to in any case!

 All three (two) points must be on a vertical or horizontal line in the plane of the wall!

 With each of the distance measurements you can use:

- a simple distance measurement,
- a value from stack/ memory or
- a measurement with time delay release.

 For short distances, a good base behind the instrument is sufficient for mechanical alignment.

 You will obtain the best results if the DISTO is rotated around a fixed point (rear edge, thread position) and the axis of the laser beam passes through this axis. So do not simply place the DISTO on a camera tripod. In this case the axis of the laser beam is approx. 70 to 100mm above the centre of rotation - this can lead to significant variations in the height.

Determination with two points

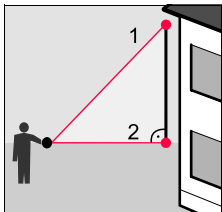

For estimating the height/width of buildings. Very useful for making measurements from standing position (no bending) if the height is determined with two or three distances.



Press until



appears on the display; laser is activated and "1 ---" starts blinking.



Aim at the upper point (1).



Trigger measurement; **do not move the instrument!**

Value is accepted.



appears on the display and "2 ---" starts blinking.

Point the DISTO approximately horizontal (2).



Press, a continuous measurement is triggered.

Move the DISTO a large amount around the ideal measurement point.



Stop of continuous measurement. The height and width are displayed from measurements (Pythagoras).

Determination with 3 points

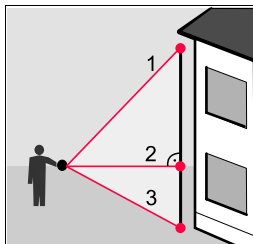

Press until



appears on the display; laser is activated and "1 ---" starts blinking.



Aim at the upper point (1).



Trigger measurement; **do not move the instrument!**

Value is accepted.



appears on the display and "2 ---" starts blinking.

Point the DISTO approximately horizontal (2).



Press, a continuous measurement is triggered.

Move the DISTO a large amount around the ideal measurement point.



Stop of continuous measurement.

Value is accepted and on the display "3 ---" starts blinking.



Aim at the lower point (3).



Trigger measurement; **do not move the instrument!**

The height and width are displayed from three measurements (Pythagoras).

Determination of a partial height with 3 points

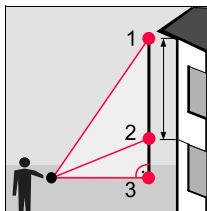

Height determination between point 1 and point 2 with three measured points.



Press until



appears on the display; laser is activated and "1 ---" starts blinking.



Aim at the upper point (1).



Trigger measurement; **do not move the instrument!**

Value is accepted and on the display "2 ---" starts blinking.



Trigger measurement; **do not move the instrument!**

Value is accepted.



appears on the display and "3 ---" starts blinking.



Press, a continuous measurement is triggered.

Move the DISTO a large amount around the ideal measurement point.



Stop of continuous measurement. The height and width are displayed between point 1 and 2 (Pythagoras).

User Information

Range

In daylight (outdoors) always work with laser viewfinder. If necessary, shade the target.

Increased range:

At night, at dusk and when target area is in the shade.

Reduced range:

By mat green and blue surfaces (also by plants or trees).

Rough surfaces

On a rough surface (e.g. coarse plaster) measure against the centre of the illuminated area.

To avoid measuring to the bottom of plaster joints:

Use target plate, 3M "Post-it" or board.

Transparent surfaces

To avoid measuring errors, do not measure towards colorless liquids (like water) or (dust free) glass.

For materials and liquids unfamiliar to you always take a trial measurement.

 When aiming through panes of glass, or if there are several objects in the line-of-sight erroneous measurements can occur.

Wet, smooth or high-gloss surfaces

- 1 Aiming at a "Acute" angle deflects the laser beam. The DISTO may receive a signal that is too weak (error message 255).
- 2 If aiming at a right angle, the DISTO may receive a signal that is too strong (error message 256).

Inclined, round surfaces

Can be measured with the laser.

Requirement: There is enough area on the target surface for the laser spot.

Free-handed aiming

(approx. 20 - 40 m):

Use target plate 563875 (DIN C6) resp. 723385 (DIN A4).

- White surface: to 30 m
- Brown surface: from 30 m on

In the field

DISTO classic⁵ is equipped with an integrated telescopic viewfinder (2x magnification).

With measurements from a distance of 25 m the laser spot is in the centre of the crosshairs. Below a distance of 25 m the laser spot moves to the edge of the crosshairs.

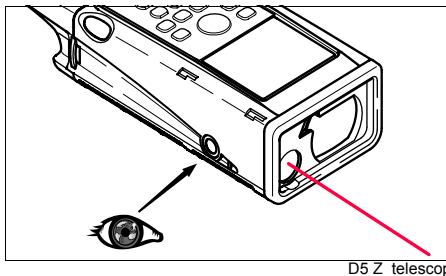

Safety Instructions

The following directions should enable the person responsible for the DISTO, and the person who actually uses the instrument, to anticipate and avoid operational hazards.

The person responsible for the instrument must ensure that all users understand these directions and adhere to them.

Use of the instrument

Permitted use

The permitted use of the DISTO are the following:

- Measuring distances
- Computing areas and volumes
- Storing measurements

Prohibited use

- Using the instrument without instruction
- Using outside the stated limits
- Deactivation of safety systems and removal of explanatory and hazard labels

- Opening of the equipment by using tools (screwdrivers, etc.), as far as not specifically permitted for certain cases
- Carrying out modification or conversion of the product
- Use after misappropriation
- Use of accessories from other manufacturers without the express approval of Leica Geosystems.
- Deliberate or irresponsible behaviour on scaffolding, when using ladders, when measuring near machines which are running, or near parts of machines or installations which are unprotected
- Aiming directly into the sun
- Deliberate dazzling of third parties; also in the dark
- Inadequate safeguards at the surveying site (e.g. when measuring on roads, etc.)



WARNING

Prohibited use can lead to injury, malfunction, and material damage. It is the task of the person responsible for the instrument to inform the user about hazards and how to counteract them. The DISTO is not to be operated until the user has been instructed.

Limits of use



See section "Technical Data"

Environment:

Suitable for use in an atmosphere appropriate for permanent human habitation. Cannot be used in an aggressive or explosive environment. Use in rain is permissible for limited periods.

Areas of responsibility

Responsibilities of the manufacturer of the original equipment Leica Geosystems AG, CH-9435 Heerbrugg (brief Leica Geosystems):

Leica Geosystems is responsible for supplying the product, including the User Manual and original accessories, in a completely safe condition.

Responsibilities of the manufacturer of non-Leica accessories:



The manufacturers of non-Leica accessories for the DISTO are responsible for developing, implementing and communicating safety concepts for their products.

They are also responsible for the effectiveness of these safety concepts in combination with the Leica Geosystems equipment.

Responsibilities of the person in charge of the instrument:



WARNING:

The person responsible for the instrument must ensure that the equipment is used in accordance with the instructions. This person is also accountable for the deployment of personnel and for their training and for the safety of the equipment when in use.

The person in charge of the instrument has the following duties:

- To understand the safety instructions on the product and the instructions in the User Manual.
- To be familiar with local safety regulations relating to accident prevention.
- To inform Leica Geosystems immediately if the equipment becomes unsafe.

Hazards in use

Important hazards in use

**WARNING:**

The absence of instruction, or the inadequate imparting of instruction, can lead to incorrect or prohibited use, and can give rise to accidents with far-reaching human, material and environmental consequences.

Precautions:

All users must follow the safety instructions given by the manufacturer and the directions of the person responsible for the instrument.

**CAUTION:**

Watch out for erroneous distance measurements if the instrument is defective or if it has been dropped or has been misused or modified.

Precautions:

Carry out periodic test measurements. Particularly after the instrument has been subject to abnormal use, and before, during and after important measurements.

Make sure the DISTO optics is kept clean and that there is no mechanical damage to the bumpers.

**WARNING:**

Insufficient securing or marking of your measurement site could cause a dangerous situation on the public highway, building site, or in the factory, etc.

Precautions:

Always ensure your measurement site is appropriately secured. Obey the local accident prevention regulations, and road safety rules, at all times.

**CAUTION:**

In using the instrument for distance measurements or for positioning moving objects (e.g. cranes, building equipment, platforms, etc.) unforeseen events may cause erroneous measurements.

Precautions:

Only use this product as a measuring sensor, not as a control device. Your system must be configured and operated in such a way, that in case of an erroneous measurement, malfunction of the device or power failure due to installed safety measures (e.g. safety limit switch), it is assured that no damage will occur.

**WARNING:**

Dispose of the equipment appropriately in accordance with the regulations in force in your country. Always prevent access to the equipment by unauthorized personnel.

**CAUTION:**

Be careful when pointing a telescope towards the sun, because the telescope functions as a burning glass and can injure your eyes and/or cause damage inside the DISTO.

Precautions:

Do not point the telescope directly at the sun.

Laser classification

The DISTO produces a visible laser beam which emerges from the front of the instrument.

It is a Class 2 laser product in accordance with:

- IEC60825-1 : 1993 "Radiation safety of laser products"
- EN60825-1 : 1994 "Radiation safety of laser products"

It is a Class II laser product in accordance with:

- FDA 21CFR Ch.I §1040 : 2001 (US Department of Health and Human Service, Code of Federal Regulations)

Laser Class 2/ II products:

Do not stare into the laser beam or direct it towards other people unnecessarily. Eye protection is normally afforded by aversion responses including the blink reflex.



WARNING:

Looking directly into the beam with optical aids (e.g. binoculars, telescopes) can be hazardous.

Precautions:

Do not look directly into the beam with optical aids.



CAUTION:

Looking into the laser beam may be hazardous to the eyes.

Precautions:

Do not look into the laser beam. Make sure the laser is aimed above or below eye level. (particularly with fixed installations, in machines, etc.)



WARNING:

Looking right at the reflected laser beam in a DISTO operated with telescopic viewfinder could be dangerous when you aim at areas that reflect like a mirror, or emit reflections unexpectedly (e.g. a mirror, metallic surfaces, windows, prisms, liquids).

Precautions:

If you are using a telescopic viewfinder, do not aim at areas that are reflective like a mirror, or which could produce unintended reflections (e.g. mirrors, metallic surfaces, windows, prisms).

Electromagnetic Compatibility(EMC)

The term "electromagnetic compatibility" is taken to mean the capability of the DISTO to function smoothly in an environment where electromagnetic radiation and electrostatic discharges are present, and without causing electromagnetic interference to other equipment.



WARNING:

Electromagnetic radiation can cause interference in other equipment.

Although the DISTO meets the strict regulations and standards which are in force in this respect, Leica Geosystems cannot completely exclude the possibility that interference may be caused to other equipment.

FCC statement (applic. in U.S.)

WARNING:

This equipment has been tested and found to comply with the limits for a Class B digital device, pursuant to part 15 of the FCC Rules. These limits are designed to provide reasonable protection against harmful interference in a residential installation.

This equipment generates, uses and can radiate radio frequency energy and, if not installed and used in accordance with the instructions, may cause harmful interference to radio communications.

However, there is no guarantee that interference will not occur in a particular installation.

If this equipment does cause harmful interference to radio or television reception, which can be determined by turning the equipment off and on, the user is encouraged to try to correct the interference by one or more of the following measures:

- Reorient or relocate the receiving antenna.
- Increase the separation between the equipment and receiver.
- Connect the equipment into an outlet on a circuit different from that to which the receiver is connected.

- Consult the dealer or an experienced radio/TV technician for help.

WARNING:

Changes or modifications not expressly approved by Leica Geosystems for compliance could void the user's authority to operate the equipment.

Product labelling:

This device complies with part 15 of the FCC Rules. Operation is subject to the following two conditions: (1) This device may not cause harmful interference, and (2) this device must accept any interference received, including interference that may cause undesired operation.

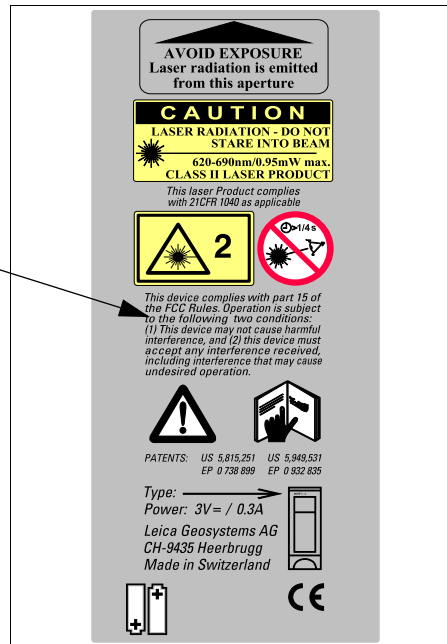

Labelling

Maximum radiant power:	0.95mW
Emitted wavelength:	620-690nm
Standard applied:	EN60825-1: 1994 IEC60825-1: 1993

D5-Z14

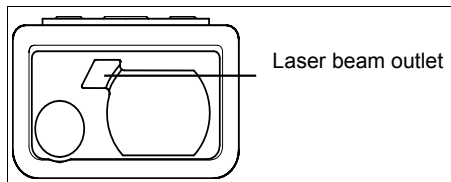

D5-Z15

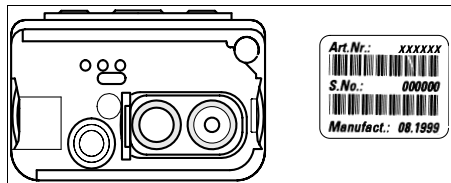

D5-Z16

AVOID EXPOSURE
Laser radiation is emitted
from this aperture

CAUTION
LASER RADIATION - DO NOT
STARE INTO BEAM
620-690nm/0.95mW max.
CLASS II LASER PRODUCT

This laser Product complies
with 21CFR 1040 as applicable

This device complies with part 15 of
the FCC Rules. Operation is subject
to the following two conditions:
(1) This device may not cause harmful
interference, and (2) this device must
accept any interference received,
including interference that may cause
undesired operation.

PATENTS: US 5,815,251 US 5,949,531
EP 0 738 899 EP 0 932 635

Type: →
Power: 3V = / 0.3A

Leica Geosystems AG
CH-9435 Heerbrugg
Made in Switzerland

D5-Z17

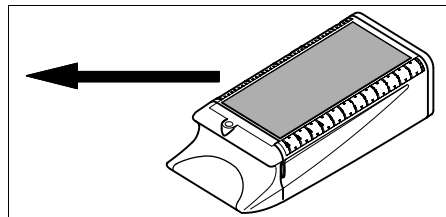

D5-Z18

Beam divergence	0.16 x 0.6 mrad
Pulse duration	15 x 10 ⁻⁹ s
Max. radiant power *	0.95 mW*
Measurement uncertainty	±5%
Max. radiant power per pulse	8 mW

CAUTION:
Allow only authorized Leica Geosystems service
workshops to service the instruments.

Technical Data

Measuring accuracy (2x standard deviation)	typ.: ± 3mm / max.: ± 5mm
Smallest unit displayed	1mm
Range	0.2m up to 200 m **
Time for a measurement dist / tracking	0.5...ca.4s / 0.16...ca.1s
∅ Laser spot (at distance)	6 / 30 / 60 mm (10 / 50 / 100 m)
Integrated telescopic viewfinder	✓
Illumination	✓
Multiline display	✓
Multifunctional bumper	✓
Time delay release	✓
Pocket calculator	✓
Tracking	✓
Constant	10 values
min./ max. Tracking.	✓
Pythagoras	✓
Memory (Stack)	15 Werte
Battery, Type AA, 2x 1.5V	up to 10'000 measurements (only with Alkaline batteries!)
Splash and dust proof	IP54 acc. IEC529: splash proof, dust proof
Dimension and weight	172 x 73 x 45 mm, 335g
Measuring accuracy of bubble	1°
Temperature range	
Storage	-25°C to +70°C (-13°F to +158°F)
Operating	-10°C to +50°C (-14°F to +122°F)

All rights reserved to make technical changes.

* Display unit as off 100m : 1 cm

** At long range ± 5 ppm (± 0.5mm/ 100 m) plus short range error.

Message Codes

Error message



appears beside the message number on the display.

Message Code	Cause	Remedy
203	Wrong sequence with Pythagoras meas.	Carry out measurement in correct sequence
204	Calculation error	Repeat procedure
252	Temperature too high, above 50°C (measuring)	Cool down instrument
253	Temperature too low, below -10°C (measuring)	Warm up instrument
255	Receiver signal too weak, measurement time too long, distance <200 mm	Use target plate measurement time >10 sec.
256	Received signal too powerful	Use target plate (correct side)

Message Code	Cause	Remedy
257	Wrong measurement, ambient brightness too high	Use target plate
260	Laser beam interrupted	Repeat measurement
	All other messages	Call service "System"



In case of this message switch on/off instrument several times and check if message is still displayed. Then call service and specify the message displayed.

Care

Look after the optical surfaces with the same care that you would apply to spectacles, cameras and field glasses.